



Smart Ammonia Sensor Device

Stox Series

Datasheet

» Overview

Easy solution for gas detection

The Stox Smart Ammonia Sensor Device is an intelligent sensor device from EC Sense, which has a 4-20mA two-wire and a RS485 Modbus RTU output signal. It uses an intelligent microprocessor with high-reliability solid polymer electrochemical gas sensor technology and intelligent algorithm calculation. The Stox Module is a smart solution for industrial safety applications, combining temperature and humidity in one sensing device.

The intelligent Gas Sensor Device provides a self-test, which evaluates the sensor performance without a gas measurement. Therefore, it is the excellent solution for smart home and IoT applications. The data is put out through the the output signal or RS485 transmission command, which makes it easy and convenient to identify the right time to perform maintenance and replacement.

Each Stox Sensor Device has been professionally calibrated with the gas. It can be instantly used without prior warm-up time and the calibration information is stored in the flash chip. There is a calibration software from EC Sense in case a recalibration should be performed with the RS485 output or the 4-20mA output signal should be corrected.

The Stox Gas Sensor Device has a standard 4-20mA two-wire or RS485 Modbus RTU output signal that allows for quick device and system setup or connection to a display, DCS, PLC and other systems.

» Key Features

- 👉 4-20mA standard two-wire and RS485 Modbus-RTU output, 24V DC. power supply
- 👉 Detects single gas + temperature and humidity at the same time
- 👉 With calibration, sensor performance
- 👉 Fast signal stability time at power on
- 👉 Suitable for indoor and outdoor environments, sensor can work in -40 to 55 °C
- 👉 Response time is fast and has a stable zero point without drift, anti-electromagnetic interference ability
- 👉 Long lifetime, anti-poisoning
- 👉 Integrated safety protection enables use in potentially explosive environments
- 👉 Electronic circuit boards have a dust and corrosion resistant coating
- 👉 Small size
- 👉 RoHS approved

» Applications

- 👉 Industrial Gas Safety Monitoring
- 👉 Industrial Process Gas Monitoring
- 👉 Environmental Monitoring of Ammonia in Farms
- 👉 Toilet Odor Monitoring
- 👉 Waste Treatment and Landfill Environment Monitoring
- 👉 Compost Monitoring
- 👉 Ammonia Leakage Monitoring in Cold Storage



» Principle

Stox Sensor Device is a durable product. It converts the original small current signals of the gas sensors into a standard 4-20mA or RS485 Modbus-RTU output through a digital circuit.

The Sensor Module uses the Solid Polymer Electrochemical Sensing Technology. It employs a three-electrode arrangement- the working, the counter and the reference electrodes- in which concentration measurements can be performed continuously and the sensor operates at a fixed potential. The gas of interest (target gas) diffuses through a diffusion barrier, like a capillary, into the cell to the working electrode, where an electrochemical reaction takes place. Oxidation and reduction reactions are happening simultaneously. The current flowing through the cell is direct proportional to the concentration of the target gas. A reference electrode keeps the potential constant together with a potentiostat.

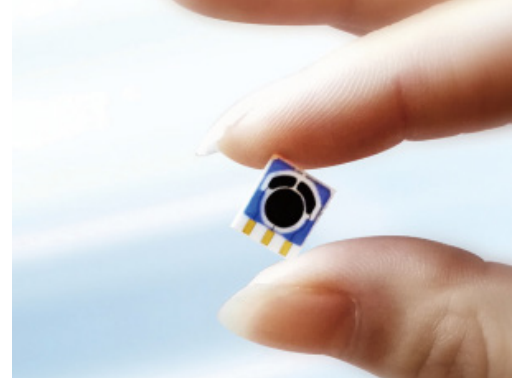

» Mechanical Drawing

Stox Series Sensor Device Mechanical Drawing

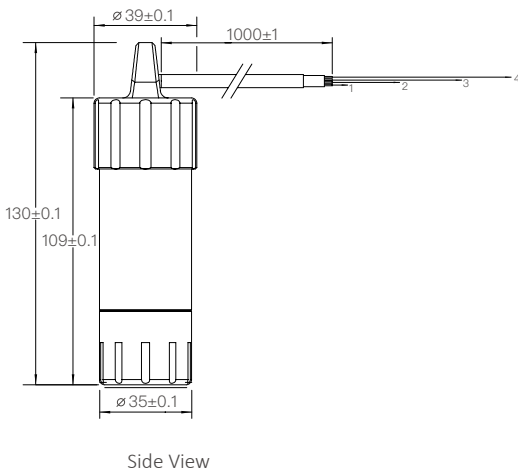
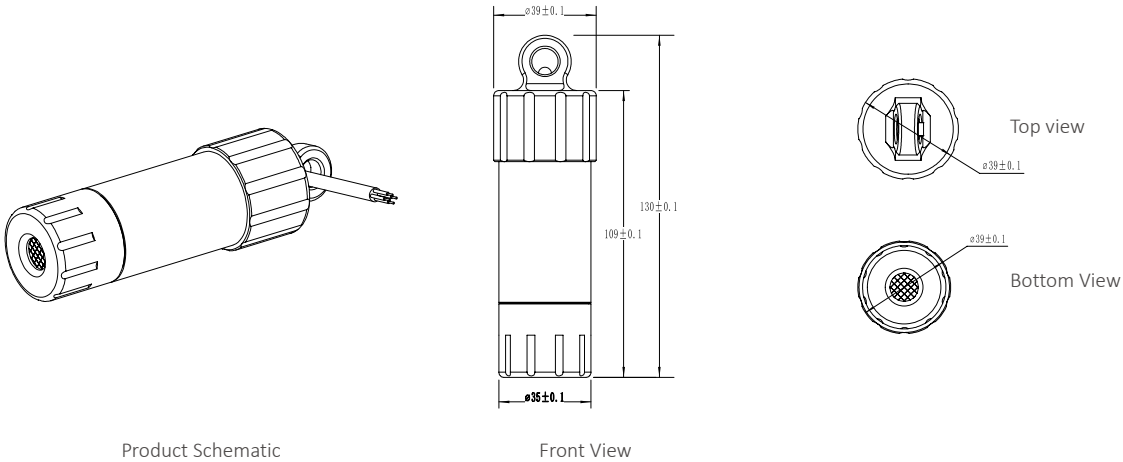

Pin	Name	Color	Description
1	VCC	Red	Power Supply
2	GND	Black	Power Supply
3	RS485 A+	Green	RS485 A+
4	RS485 B-	White	RS485 B-

» Technology Specifications

Gas Sensor Specifications

Principle	Solid Polymer Electrochemical Sensing Technology
Accuracy	± 5 % Full scale
Repeatability	< 2%
Linearity	Linear
Long-Term Drift	< 1% / month
Expected Lifetime	> 3 years

Temperature & Relative Humidity Sensor Specification

Parameter	Range	Resolution	Accuracy	Repeatability	Response Time	Long-Term Drift
Temperature	-40 to 85°C	0.01°C	± 0.2°C	0.1°C	< 5s to 30s @ t63%	< 0.02°C /year
Humidity	0-100% RH	0.01% RH	± 2% RH	0.1% RH	8s @ t63%	< 0.25% RH/year

Electrical Specifications

Optional Output Signal	4-20mA two-wires (Only gas sensor output, without temperature and humidity) Or RS485 Modbus-RTU (Gas with temperature and humidity sensor signal output)
Fault Output	3.5mA Fault Signal: Sensor signal weak 3mA Fault Signal: Sensor failure or sensor disconnected RS485 Modbus-RTU output with sensor life and performance detection and early sensor failure warning
Supply Voltage	12 to 24V DC
Supply Current	3 to 22mA
Power Consumption	< 0.6W
Maximum Loop Resistance	< 500R @ 24V DC

Environment Specifications

Operating Temperature	Sensor can work from -40 to +55°C
Operating Humidity	15-95% RH. Non-condensing
Operating Pressure	Atmospheric pressure ± 10%
Storage Temperature	0 to 20°C

Mechanical Specifications

Size	39 x 130mm
Weight	135g
Power Cable length	1m
Warranty	12 months
Package Size	185 x 150 x 108mm

» Order Information

Product	Gas Formula	Partnumber	Range	Resolution	Response Time
Smart Carbon Monoxide Sensor Device	CO	05-Stox-CO-10-01	0-10ppm	0.01ppm	< 3s (T90 < 80s)
		05-Stox-CO-100-01	0-100ppm	0.1ppm	< 3s (T90 < 30s)
		05-Stox-CO-1000-01	0-1000ppm	1ppm	< 3s (T90 < 30s)
		05-Stox-CO-10000-01	0-10000ppm	10ppm	< 3s (T90 < 30s)
Smart TVOC Sensor Device	TVOC	05-Stox-TVOC-10-01	0-10ppm	0.01ppm	< 3s (T90 < 30s)
		05-Stox-TVOC-200-01	0-200ppm	0.1ppm	< 3s (T90 < 30s)
		05-Stox-TVOC-2000-01	0-2000ppm	1ppm	< 3s (T90 < 30s)
		05-Stox-TVOC-10000-01	0-10000ppm	10ppm	< 3s (T90 < 30s)
Smart Hydrogen Floride Sensor Device	HF	05-Stox-HF-10-01	0-10ppm	0.01ppm	< 3s (T90 < 80s)
Smart Hydrogen Sulfide Sensor Device	H ₂ S	05-Stox-H ₂ S-10-01	0-10ppm	0.01ppm	< 3s (T90 < 30s)
		05-Stox-H ₂ S-100-01	0-100ppm	0.1ppm	< 3s (T90 < 30s)
		05-Stox-H ₂ S-1000-01	0-1000ppm	1ppm	< 3s (T90 < 30s)
		05-Stox-H ₂ S-5000-01	0-5000ppm	1ppm	< 3s (T90 < 30s)
Smart SMELL Sensor Device	SMELL	05-Stox-SMELL-5-01	0-5ppm	0.01ppm	< 3s (T90 < 30s) ①
		05-Stox-SMELL-200-01	0-200ppm	1ppm	< 3s (T90 < 30s)
Smart Nitrogen Dioxide Sensor Device	NO ₂	05-Stox-NO ₂ -5-01	0-5ppm	0.01ppm	< 3s (T90 < 80s) ①
		05-Stox-NO ₂ -100-01	0-100ppm	0.1ppm	< 3s (T90 < 30s)
Smart Sulphur Dioxide Sensor Device	SO ₂	05-Stox-SO ₂ -5-01	0-5ppm	0.01ppm	< 3s (T90 < 80s) ①
		05-Stox-SO ₂ -100-01	0-100ppm	0.1ppm	< 3s (T90 < 30s)
Smart Chlorine Sensor Device	Cl ₂	05-Stox-Cl ₂ -10-01	0-10ppm	0.01ppm	< 3s (T90 < 30s) ①
		05-Stox-Cl ₂ -100-01	0-100ppm	0.1ppm	< 3s (T90 < 30s)
Smart Ethylene Oxide Sensor Device	ETO	05-Stox-ETO-10-01	0-10ppm	0.01ppm	< 3s (T90 < 30s) ①
		05-Stox-ETO-200-01	0-200ppm	0.1ppm	< 3s (T90 < 30s)
		05-Stox-ETO-1000-01	0-1000ppm	1ppm	< 3s (T90 < 30s)
Smart Phosphane Sensor Device	PH ₃	05-Stox-PH ₃ -5-01	0-5ppm	0.01ppm	< 3s (T90 < 80s) ①
		05-Stox-PH ₃ -100-01	0-100ppm	0.1ppm	< 3s (T90 < 80s)
		05-Stox-PH ₃ -2000-01	0-2000ppm	1ppm	< 3s (T90 < 80s)
Smart Formaldehyde Sensor Device	HCHO	05-Stox-HCHO-5-01	0-5ppm	0.01ppm	< 3s (T90 < 80s) ①
		05-Stox-HCHO-100-01	0-100ppm	0.1ppm	< 3s (T90 < 60s)
Smart Methanethiol Sensor Device	CH ₄ S	05-Stox-CH ₄ S-10-01	0-10ppm	0.01ppm	< 3s (T90 < 80s)
		05-Stox-CH ₄ S-100-01	0-100ppm	0.1ppm	< 3s (T90 < 80s)
		05-Stox-CH ₄ S-5000-01	0-5000ppm	10ppm	< 3s (T90 < 80s)
Smart Ethylene Sensor Device	C ₂ H ₄	05-Stox-C ₂ H ₄ -10-01	0-10ppm	0.01ppm	< 3s (T90 < 80s) ①
		05-Stox-C ₂ H ₄ -200-01	0-200ppm	0.1ppm	< 3s (T90 < 80s)

»» Order Information

Product	Gas Formula	Partnumber	Range	Resolution	Response Time
Smart Hydrogen Cyanide Sensor Device	HCN	05-Stox-HCN-50-01	0-50ppm	0.1ppm	< 3s (T90 < 30s) ①
Smart Arsine Sensor Device	AsH ₃	05-Stox-AsH ₃ -5-01	0-5ppm	0.01ppm	< 3s (T90 < 80s) ①
Smart Silane Sensor Device	SiH ₄	05-Stox-SiH ₄ -10-01	0-10ppm	0.01ppm	< 3s (T90 < 80s) ①
Smart Diborane Sensor Device	B ₂ H ₆	05-Stox-B ₂ H ₆ -5-01	0-5ppm	0.01ppm	< 3s (T90 < 80s) ①
Smart Germane Sensor Device	GeH ₄	05-Stox-GeH ₄ -5-01	0-5ppm	0.01ppm	< 3s (T90 < 80s) ①

Note: 1) Please contact us for any gases not in the list above.

2) For gases with ①, TB90 response time is calculated from the time the sensor comes into contact with the gas.

3) For gases with ①, linearity is $\pm 10\%$ F.S.

Disclaimer

The EC Sense performance data stated above is based on data obtained under test conditions using the EC Sense gas distribution system and AQS test software. In the interest of continuous product improvement, EC Sense reserves the right to change design features and specifications without notice. We are not responsible for any loss, injury or damage caused by this. EC Sense assumes no responsibility for any indirect loss, injury or damage resulting from the use of this document, the information contained therein or any omissions or errors herein. This document does not constitute an offer to sell. The data it contains are for informational purposes only and cannot be considered a guarantee. Any use of the given data must be evaluated and determined by the user to comply with federal, state and local laws and regulations. All specifications outlined are subject to change without notice.

Warning

EC Sense sensors are designed for use in a variety of environmental conditions. However, due to the principles and characteristics of solid polymer electrochemical sensors and to ensure normal use, users must strictly follow this article during storage, assembly and operation of the module. General-purpose PCB circuit board application methods and illegal applications / violation of the application will not be covered by the warranty. Although our products are highly reliable, we recommend checking the module's response to the target gas prior to utilization to ensure on-site use. At the end of the products service life, please do not discard any electronics in the domestic waste, instead follow the local governments electronic waste recycling regulations for disposal.



Business Centre
Europe and the Rest of the World

EC Sense GmbH
Wangener Weg 3
82069 Hohenschäftlarn, Germany



Distributor
WOOFAA Company Limited

Unit 1006, 10/F, Kingsford Industrial Centre,
13 Wang Hoi Road, Kowloon Bay, Hong Kong
Tel: +852 2649 4000
Fax: +852 3007 5188
Email: hotline@woofaa.com
Web: www.woofaa.com